

739 Shop Oven



Available in gas, oil or electrically heated models.
Max tray size: 8 trays - 18" x 26"

The unique technology in a Revent oven will take your baking quality to an even higher level.

Revent TCC System (Total Convection Control)
Revent HVS System (High Volume Steam)

Revent[™]
More than Quality.

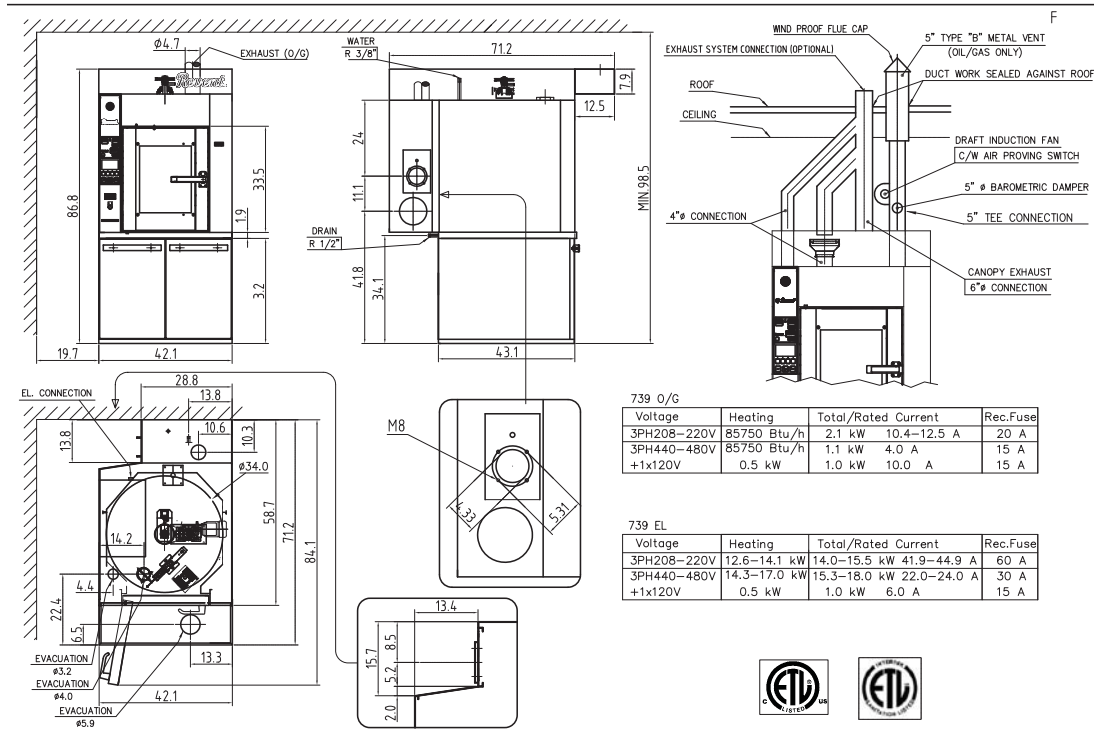

701035 A

Specifications	MINI 739 Oven	MINI 739 Proofer
Tray size	18" x 26"	18" x 26"
Number of trays	8	16 (2 x 8)
Height between runners	3.43"	3"
Weight lbs	936	441
Temperature range °F	95 - 572	38 - 86
Relative humidity		80%
Thermostat	Digital	Digital
Heat up time - minutes	~30	~30
Damper Control	Yes	
Heating capacity BTU	85000	0,5 kW
Electrical connection	3 phase	-
Water supply	1/2" NPT 3.56 psi	-
Oven damper exhaust	ø 4"	-
Drain	1/2 "	-
Oven stack exhaust o/g	ø 5"	-
Oven over pressure	3.15"	-
Canopy exhaust	6"	-

Continuous product development is a Revent policy. Therefore, we reserve the right to change specifications and/or design without prior notice. Pictures or drawings may include product options.

Revent sales representative:



Revent Incorporated
100 Ethel Road West, Piscataway, New Jersey 08854
Phone (732) 777-9433, Fax (732) 777-1187
Toll Free 800-822-9642
E-mail info@revent.com, www.revent.com